

Simulation of Fatigue Crack Growth of Locally Machined Bolts in Nigeria

Ogwuagwu Obiajulu Vincent

Department of Mechanical Engineering, Federal University of Technology
Minna, Niger State, Nigeria
<ovogwuagwu@yahoo.com>

Abstract

A simulation study of the fatigue fracture and failure characteristics of locally machined bolts is presented. The numerical results obtained show that the bolts have low stress intensity factor as well as load cycles before failure. Recommendation was made on how to improve on these properties.

Keywords: Fatigue fracture, stress intensity factor, threshold stress intensity factor.

Introduction

The evolution of small-scale enterprises in the country has led to the setting up of many small machine shops involved in the production of bolts and nuts, as well as power screws. These bolts and nuts are usually machined from carbon steel bar stocks and are never treated after machining. Also, because there are no quality control measures involved in the production process, some of these bolts get into the market with surface cracks at the root of the threads.

The use of these bolts always lead to premature failure even when the machine is not operation, ie. During the assembling process of the machine parts. This has necessitated the simulation of the fatigue crack growth and fracture failure characteristics of such bolts.

There are analytical and semi analytical methods for fracture analysis such as those used by Delale and Erdogan (1983), Erdogan (1995), Chan *et al.* (2001) and Erdogan and Wu (1997) in their studies. The problem of fracture can also be associated with grain size, shape as well as grain boundaries orientations (Evans and Feler). Since the machined bolts are not treated after machining, the role of material characteristics in fracture failure of these bolts is also a major factor.

Problem Formulation

Fig. 1 shows the model of a bolt under load. Using the linear fracture mechanics, the direction criteria may be dependent upon the fracture criterion (Erdogan and Sih 1963). However, in the case of elastic-plastic fracture mechanics, the direction criterion likely to be dependent on upon the state of stress or strain at the crack tip.

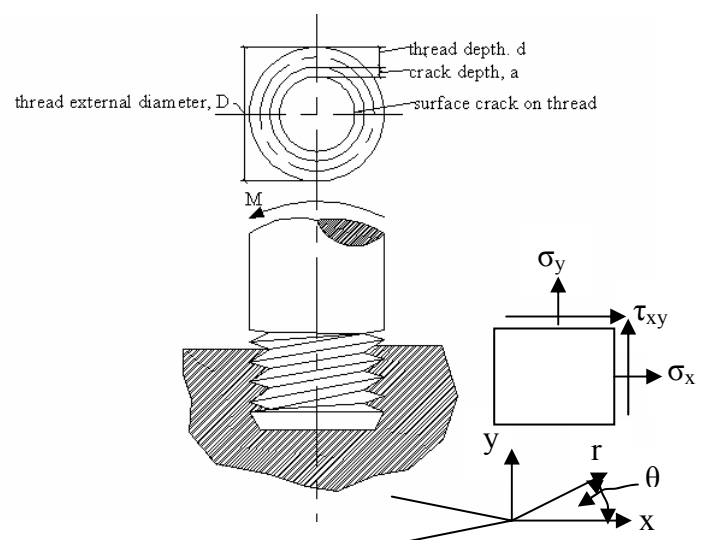

Fig. 1. Model of a bolt under load

In polar coordinates, the stress or strain in a linear elastic cracked body may be represented as

$$\sigma_{ij} = \left(\frac{k}{\sqrt{r}} \right) f_{ij}(\theta) + \sum_{n=0}^{\infty} A_n r^{\frac{n}{2}} c_{ij}^n(\theta) \quad (1)$$

Where σ_{ij} is the stress tensor and r and θ defines a given point in the body in polar coordinates in relation to the crack and k is a constant (stress intensity factor) Both f_{ij} and c_{ij} are all functions of θ . For mode I crack equation (1) reduces to the form

$$\sigma_{ij} = \frac{k_I}{\sqrt{2\pi r}} \quad (2)$$

The following stress and displacement fields are obtained for $n \leq 2$

$$\sigma_{xx} = \frac{k_I}{\sqrt{2\pi r}} \cos \frac{\theta}{2} \left(1 - \sin \frac{\theta}{2} \sin \frac{3\theta}{2} \right) = \frac{k_{II}}{\sqrt{2\pi r}} \sin \frac{\theta}{2} \left(2 + \cos \frac{\theta}{2} \cos \frac{3\theta}{2} \right) \quad (3)$$

$$\sigma_{yy} = \frac{k_I}{\sqrt{2\pi r}} \cos \frac{\theta}{2} \left(1 + \sin \frac{\theta}{2} \sin \frac{3\theta}{2} \right) + \frac{k_{II}}{\sqrt{2\pi r}} \cos \frac{\theta}{2} \sin \frac{3\theta}{2} \quad (4)$$

$$\tau_{xy} = \frac{k_I}{\sqrt{2\pi r}} \cos \frac{\theta}{2} \sin \frac{3\theta}{2} + \frac{k_{II}}{\sqrt{2\pi r}} \cos \frac{\theta}{2} \left(1 - \sin \frac{\theta}{2} \sin \frac{3\theta}{2} \right) \quad (5)$$

Also,

$\sigma_{zz} = 0$ for plain stress and

$\sigma_{zz} = \nu(\sigma_{xx} + \sigma_{yy})$ for plain strain.

Equations (3) through (5) above are of $O(r^{1/2})$ accuracy..

For solid circular sections the relation for the crack size c is given by

$$c = r \tan^{-1} \left[\frac{a(2r - a)}{2r(r - a)} \right] \quad (6)$$

$$\theta = \frac{c}{r} \quad (7)$$

Where c is crack length in the peripheral direction.

Results and Discussion

In the numerical simulation, properties of low carbon steel were used since these bolts are usually machined from these steels.

Fig. 2 shows the variation of crack size c with number of loading cycles while Fig. 3 show the variation of stress intensity factor k with number of loading cycles. Fig. 4 through 6 shows the crack growth rate, c , threshold stress intensity factor, Δk_{th} and ratio of the threshold

stress intensity factor Δk_{th} and the stress intensity factor Δk with number of cycles of loading.

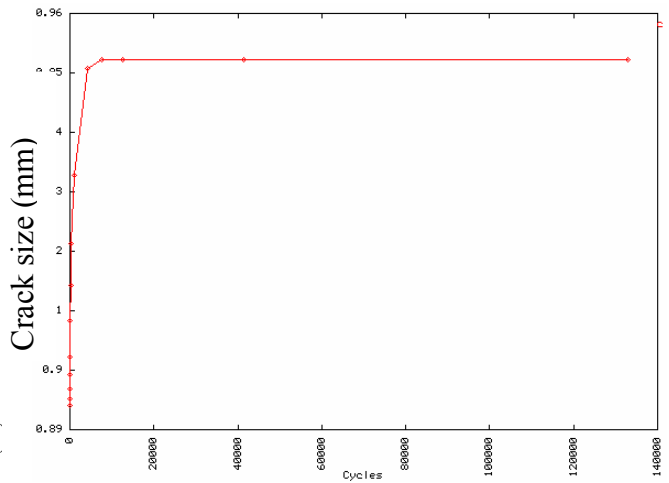

Fig. 2. Variation of crack size c with loading cycles

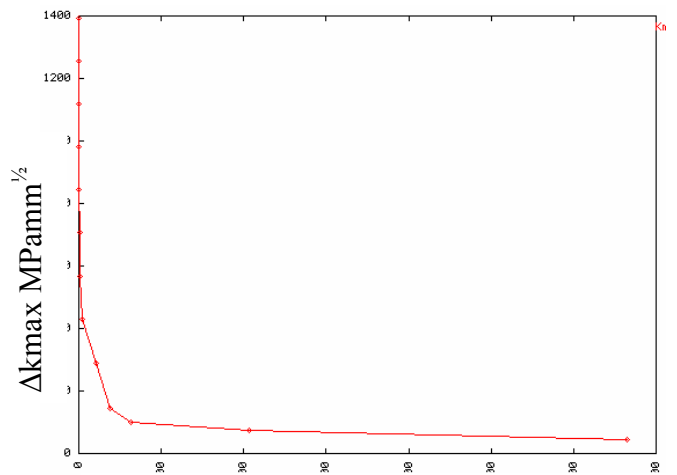

Fig. 3. Variation of stress intensity factor ΔK_{max} with number of cycles N

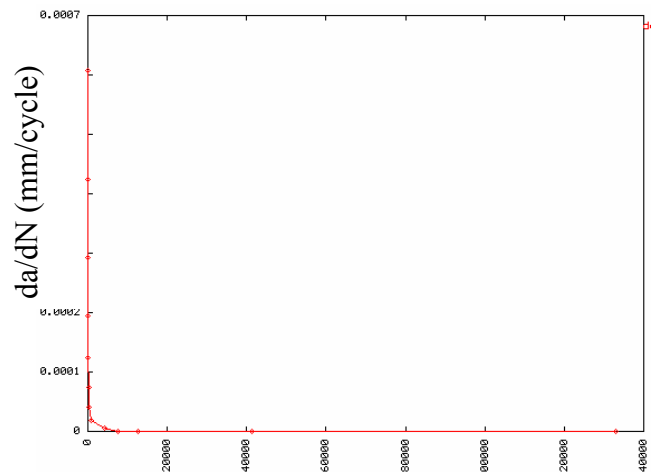

Fig. 4. Crack growth rate c , with number of cycles N

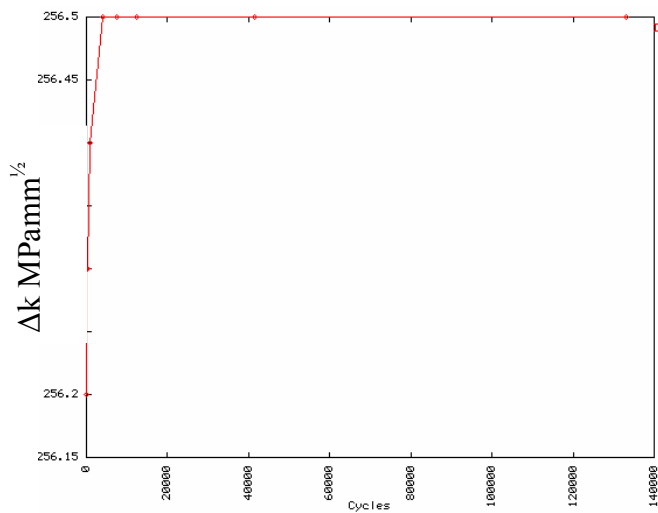

Fig. 5. Variation of Threshold stress intensity factor Δk

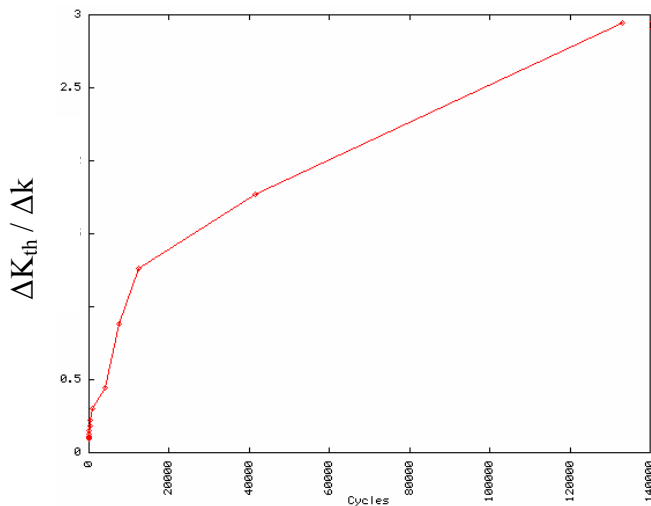

Fig. 6. Variation of ration the threshold stress intensity, Δk_{th} factor to stress intensity factor Δk

From Fig. 2, the crack size, c stabilized after about 20,000 cycles of loading. Fig. 3 shows that the bolts have very low stress intensity factor, Δk of about $43.52 \text{ MPa mm}^{1/2}$. This explains the high rate of bolt failure being experienced while in use. This phenomenon is attributable to the lack of treatment of the bolts after machining.

From Fig. 4, the rate of change of crack size, c is zero even before the bolt attained 20,000 cycles of loading. At this point, the rate of growth of the crack size c is about 4.505×10^{-7} .

The threshold stress intensity factor Δk_{th} as shown in Fig. 5. is $256.5 \text{ MPa mm}^{1/2}$.

The variation of ration of the stress intensity factor to the threshold stress intensity factor as shown in Fig. 6 is smooth at the early stage. However, the slope of the curve changed after about 13,300 cycles of loading.

Conclusion

The behavior of the bolt is largely attributable to the non treatment of these bolts after machining. The ratio of growth increment on current crack size, c is about 0.005. At abbot 13,300 cycles of loading most of the bolt failure characteristics have changed remarkably, although at this stage, the critical crack size has not been attained.

References

- Chan, Y.S., Paulino, G.H. and Fannjiang, A.C. 2001. The crack problem for a non-homogeneous material under antiplane shear loading – A displacement based formulation. *Int. J. Solid Struct.* 38: 2989-3005.
- Delale, F.; and Erdogan, F. 1983. The crack problem for a non-homogeneous phase. *J. Appl. Mechan. (ASME)* 50: 609-14.
- Erdogan, F. 1995. Fracture mechanics of functionally graded materials. *J. Composite Engin.* 5: 753-70.
- Erdogan, F.; and Sih, G.C. 1963 On the crack extension in plates under plane loading and transverse shear. *J. Basic Engin.* Vol. 2: 519-27.
- Erdogan, F.; and Wu, B.H. 1997. The surface crack problem for a plat with functionally graded properties. *J. Appl. Mechan. (ASME)* 50: 449-56.