

# The Best Biobriquette Dimension and its Particle Size

H. Saptoadi

Department of Mechanical & Industrial Engineering  
Gadjah Mada University, Yogyakarta, Indonesia  
[harwins@ugm.ac.id](mailto:harwins@ugm.ac.id) and [harwins@lycos.com](mailto:harwins@lycos.com)

**Abstract:** Indonesia has abundant supply of biomass, where some portions become waste after its utilization. In order to minimize environmental pollution and extract its energy content, the waste must be burned. However it can not be used directly due to its disadvantageous characteristics. Normally it is densified in form of briquettes.

Some experiments have been carried out to investigate the best briquette dimension. Briquettes are formed cylindrical with a diameter of 13 mm and made from 75% of wooden saw dust added with 25% of lignite in order to improve its heating value and combustibility. Additionally they are mixed with 40% natural binder. In order to obtain the same initial weight of the briquette group, the following amount of biobriquettes are selected: 20 pieces of 3 gram briquette, 15 pieces of 4 gram briquette, and 12 pieces of 5 gram briquette. Combustion air are supplied with three different velocities (i.e. 0.3 m/s, 0.4 m/s, and 0.5 m/s), meanwhile its temperature is held

constant at 70°C. Those biobriquettes are placed onto a 11.7 cm diameter perforated plate which is located within a cylindrical combustion furnace where combustion air flows upward. The plate is suspended by a wire which hangs down from a constantly measuring electronic scale. As expected, it is concluded that smaller biobriquettes produce better combustion characteristics (especially combustion rate) due to larger specific surface area available for reaction.

Other experiments have been conducted to investigate the influence of particle sizes which come together to form biobriquettes, however rice husk is used entirely to create the biobriquettes. There are 5 different particle sizes, i.e. more than 100 mesh, between 70 and 80 mesh, between 60 and 70 mesh, between 50 and 60 mesh, and between 40 and 50 mesh. The investigations reveal that the smaller the particle size, the lesser will be the porosity, and on the contrary, the more will be the density. Briquettes made from coarser rice husks tend to expand more significantly shortly after released from the briquetting machine. Results from the combustion tests show that lower porosities will hinder drying, devolatilization and char burning processes due to fewer free spaces for mass diffusion. Consequently its combustion rates will be lower. The combustion period will be longer. On the average, briquettes from the largest particle burn only for 19.25 s, while those from the smallest particle react until 28 s. Furthermore more unburned carbon is left at the combustion termination, i.e. only 16% for briquettes from the largest particle compared to 33% for briquettes from the tiniest particles.

It can be concluded from those experiments that briquette dimensions should be as small as possible but their composing particles should be as coarse as possible. Combining those requirements, each briquette should be an impervious single very small unit.

**Keywords:** Biomass, Briquette, Combustion, Diffusion, Particle size, Porosity, Surface area..

## INTRODUCTION

As a fertile country with 6 month rainy season, Indonesia has abundant supply of biomass. However some portions of it become waste after its primary utilization. Several common examples of these organic wastes are rice husk, rice straw, coconut fiber, coconut shell, palm oil shell, palm oil fiber, bagasse, wood chip, saw dust, etc. Actually these wastes can still be used later on either as natural fertilizer, or as high valued handicrafts or building materials. Alternatively, in order to minimize environmental pollution and also to extract its energy content, the wastes can be burned. Biomass is fortunately a clean and renewable energy source. However it can not be burned directly due to its disadvantageous characteristics, e.g. low energy density and problems in handling, storage and transportation. Normally it is densified in form of soft pellets called biobriquettes to improve the energy density, to increase the heat capacity (the capability to retain heat for a longer period and maintain higher temperatures to facilitate easy ignition of fresh fuel charges), and to

reduce the amount of flying ash (because more ash is bound within its char). Biomass briquettes can have higher density (almost twice) than common wood. Sometimes small amount of conventional solid fuel, such as coal or char, is added into biomass briquettes to improve its heating value and combustibility [1]. On the contrary, another research result shows that in terms of energy output and pollutant emissions, such as particulate matters, CO, CO<sub>2</sub>, SO<sub>2</sub> and NO<sub>x</sub>, the optimum blending ratio of biomass with coal is between 10% and 30% [2]. Meanwhile the author, after some simple investigations, prefers the mixing ratio of 1 : 3 for coal and biomass [3], as used in this research.

Biobriquettes can be used either for heat generation in households and small scale home industries, or even for power generation in large industries [4,5]. Consequently different types of furnace are required according to heat release rates, briquette dimensions, fuel heating values, etc. Whatever the purpose of the briquette, it is expected that the highest possible reaction rate is maintained during combustion. The reaction rates are obviously resulted from complex interaction of many variables.

The conducted researches aim to reveal influences of biobriquette dimension and size of its composing particles on the combustion rates. Although almost similar experiments have been carried out by many researchers previously, yet it is demanded that the results can greatly contribute to further improvement of fuel briquette technology.

## METHODOLOGY

Two different experiments have been carried out in order to investigate the influences of briquette dimension (Experiment 1) and composing particle size (Experiment 2) on the fuel combustion characteristics.

### 1. Materials

The required materials for the first experiment are wooden saw dust, lignite and natural binder. Briquettes are formed cylindrical with a diameter of 13 mm and made from 75% of wooden saw dust added with 25% of lignite. Additionally they are mixed with 40% natural binder (made from 16.6% cassava starch and 83.3% water). There are three different briquette masses, i.e. 3 g, 4 g and 5 g, respectively, ready for examinations.

Meanwhile the second experiment involves only rice husk as the investigated burning material and natural binder (consist of 9.1% cassava starch and 90.9% water). Five different particle sizes are prepared, i.e. more than 100 mesh (smaller than 150 microns), between 70 and 80 mesh (between 180 and 212 microns), between 60 and 70 mesh (between 212 and 250 microns), between 50 and 60 mesh (between 250 and 300 microns), and between 40 and 50 mesh (between 300 and 425 microns). The ratio between rice husk and binder is 3 : 1, and all the wet briquettes weigh initially 4 grams in the form of 16 mm diameter cylinders. Figure 1 shows some examples of these rice husk briquettes.

Those briquettes are made using a simple manual unheated

briquetting machine with replaceable molds (according to required briquette dimension and geometry), as shown in Figure 2. By clock wise turning of the upper wheel, the pushing piston will be lowered and gradually pressing the materials within the mold until a certain degree of briquette compactness is reached.



**Figure 1.** Rice husk briquettes.



**Figure 2.** Briquetting machines.

## 2. Equipments

The simple schematic diagram of the combustion apparatus used for both experiments is shown in Figure 3.

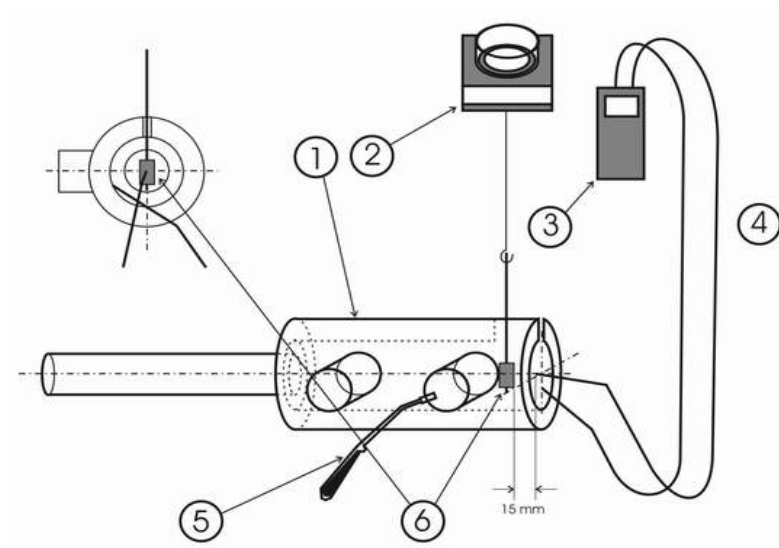

Legend :

1. Combustion furnace, where the briquettes are reacted with incoming hot combustion air.

2. Digital scale to measure continuously the remaining mass of the briquettes.

3. Digital thermometer to read the temperatures of air, hot gas and furnace wall.

4. Thermocouple to monitor the temperatures of air, hot gas and furnace wall.

5. Heating torch to heat the combustion air (first experiment) or the furnace wall (second experiment).

6. Fuel briquette.

**Figure 3.** Schematic diagram of the combustion equipment.

For the first experiment, however, briquettes are placed onto a 11.7 cm diameter perforated plate which is located within a cylindrical combustion furnace where combustion air flows upward through several holes in the plate. Furthermore, a blower is provided to supply combustion air with various velocities.

### **3. Procedures**

For the first experiment : In order to obtain the same initial weight of the briquette group, i.e. 60 grams, the following amount of biobriquettes are selected : 20 pieces of 3 gram wet briquette, 15 pieces of 4 gram wet briquette, and 12 pieces of 5 gram wet briquette. Combustion air are supplied with three different velocities (i.e. 0.3 m/s, 0.4 m/s, and 0.5 m/s), meanwhile its temperature is held constant at 70°C with the help of an air preheater, which uses an LPG burner as heat source.

For the second experiment: The fuel specimen is reacted one at a time in the cylindrical furnace. The furnace wall temperature is held constant, approximately 283°C, during the measurements. The flue gas temperature at a position of about 1.5 cm behind the burning fuel is observed and considered to be constant at roughly 135°C. The combustion air at room temperature flows naturally.

The instantaneous masses for both experiments are recorded for every 15 seconds. Instantaneous combustion rates are derived by calculating the mass reduction (or mass difference) during these 15 seconds. The measurements are terminated if there is no mass decrease anymore.



The effect of buoyancy force due to upward motion of combustion air is neglected because the required data are recorded briquette mass differences for a certain time period. Assuming that the upward force is always constant (because the air velocity is also unchanged during the observations), the measured mass differences represent solely the mass decrease of the burning briquettes.

## RESULTS AND DISCUSSIONS

### 1. The first experiment

The results of combustion rate calculations are displayed in the following Figure 4, Figure 5 and Figure 6. However, since the real process is highly fluctuated during the reaction period and thus make analyses very difficult, the oscillating curves are mathematically smoothed.

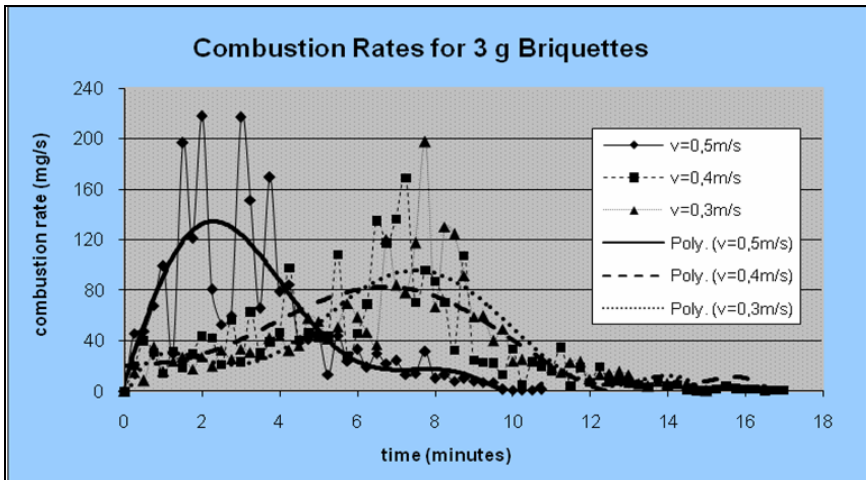

**Figure 4.** Combustion rates for 20 pieces of 3 gram biobriquettes.

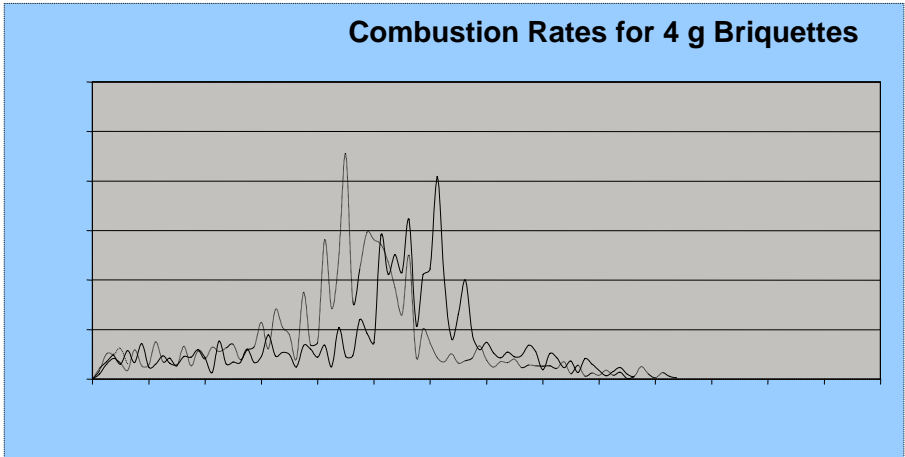

**Figure 5.** Combustion rates for 15 pieces of 4 gram biobriquettes.

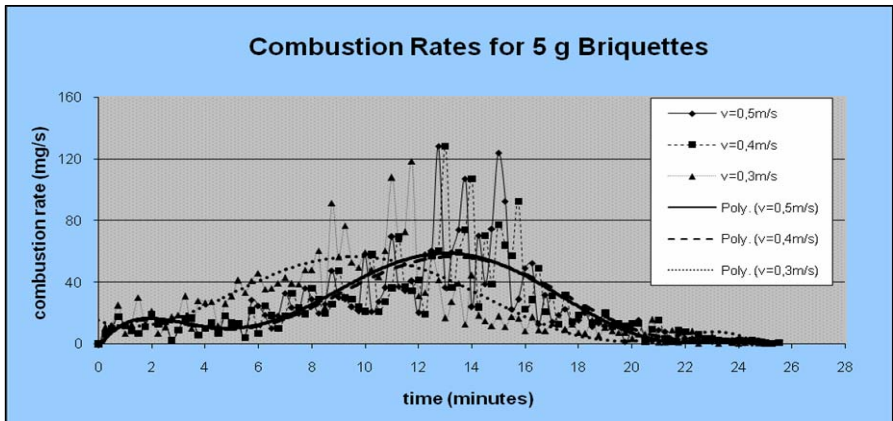

**Figure 6.** Combustion rate for 12 pieces of 5 gram biobriquettes.

The 3 gram briquettes demonstrate the highest maximum combustion rates (about 135 mg/s at  $v = 0.5$  m/s, and around 90 mg/s at lower air velocities) and the corresponding reaction periods are the shortest one (between 10 and 16 minutes). On the contrary, the 5

gram briquettes exhibit the lowest maximum combustion rates (only about 55 mg/s at all air velocities), while their reaction periods are the longest ones (until 26 minutes). As expected, the 4 gram briquettes perform in between those of 3 gram and 5 gram ones.

It is interesting to note that the 3 gram briquettes require the highest amount of air, i.e. at 0.5 m/s, in order to perform at its best, where lower air supply will reduce its reaction rate and lengthen its reaction period. If the briquettes are enlarged, i.e. with a mass of 4 gram, the optimum amount of air supply will shift to 0.4 m/s. And the trend continues, where even larger briquettes (each weighs 5 gram) necessitate even smaller amount of air (at 0.3 m/s) to burn most efficiently.

Therefore, by comparing those three figures, particularly their smoothed curves, it can be easily concluded that a group of smaller biobriquettes demonstrate better combustion characteristics (especially combustion rate) due to larger specific surface area available for reaction. More accessible surface area will obviously facilitate more oxygen in air to bind carbon in a certain time period. Therefore the larger the specific surface area, the shorter it will take to burn the briquettes. Optimum amount of combustion air is noticed in these 3 figures. Too small amount of air will decrease the combustion rate due to oxygen shortage, but too much air will reduce the combustion rate as well because of excessive convective cooling. Arrhenius states that combustion rate depends strongly on briquette temperature.

## **2. The second experiment**

The produced rice husk briquettes exhibit the following

physical and reaction characteristics, as shown in Table 1. The table includes some results of combustion tests as well.

**Table 1.** Characteristics of biobriquettes.

Particle size (microns)	150	180 -212	212 - 250	250 - 300	300 - 425
Briquette mass (gram)	2.926	2.629	2.691	2.539	2.798
Briquette height (mm)	15.95	18.00	18.30	20.75	23.90
Briquette diameter (mm)	15.75	16.00	16.60	17.10	17.40
Briquette volume (mm <sup>3</sup> )	3108.8	3620.6	3962.2	4767.3	5685.4
Briquette density (kg/m <sup>3</sup> )	941.2	726.1	679.2	532.6	492.1
Strain (%)	32.92	38.46	40.77	48.21	70.71
Reacted mass (gram)	1.963	2.148	2.159	2.137	2.332
Unburned mass (%)	32.91	18.30	19.77	15.83	16.65
Combustion time (min)	28.0	25.5	24.0	22.0	19.25

Meanwhile the mathematically smoothed combustion rates of those five different briquettes, which are composed of five different particle finenesses, are displayed in the following Figure 7.

The investigations reveal that particle sizes determine briquette porosities. The smaller the particle size, the higher will be the density, and on the contrary, the lesser will be the porosity. The lowest density is 492.1 kg/m<sup>3</sup>, while the highest is 941.2 kg/m<sup>3</sup>. Briquettes made from coarser rice husks tend to expand more significantly shortly after released from the briquetting machine. The strain percentages show the phenomenon, where the finest particles will force the briquette to elongate 32.9% while the largest particles can reach 70.7%. The strain reflects the porosity as well.

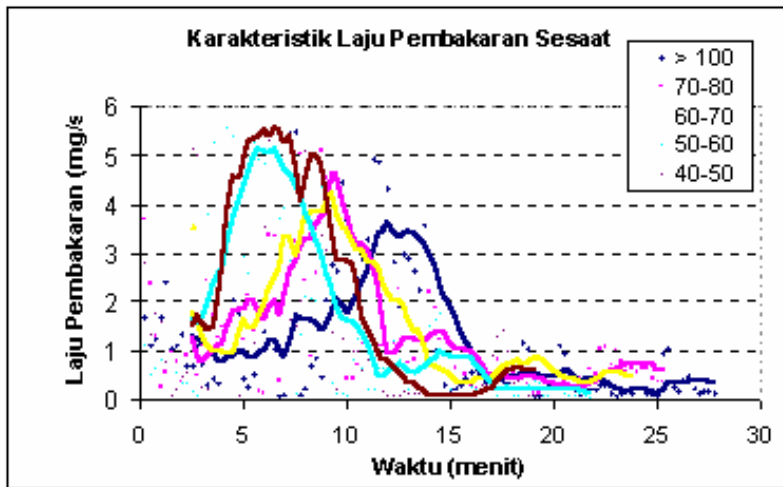

**Figure 7.** Instantaneous combustion rates of different particle sizes.

Results from the combustion tests show that lower porosities will hinder mass transfer, such as drying, devolatilization and char burning processes, due to fewer free spaces for mass diffusion (e.g. water vapor, volatile matter, and carbon dioxide outflows and simultaneously oxygen infiltration). Consequently its combustion rates (briquette weight reduction rates) will be lower (see figure 7). The combustion period will be longer. On the average, briquettes from the largest particle burn only for 19.25 minutes, while those from the smallest particle react until 28 minutes. Furthermore more unburned carbon is left at the combustion termination, i.e. only 16% for briquettes from the largest particle compared to 33% for briquettes from the tiniest particles.

### 3. The appropriate furnace

The most appropriate furnace type for the discussed biobriquettes

is either suspension burning (crushed fuel) or fluidized bed, particularly CFB (circulating fluidized bed). However fluidized bed type can be better, considering that there is no need to provide expensive pulverizing system because relatively coarser briquettes are still acceptable. Moreover the resulted lower temperature within the fluidized bed combustion chamber is suitable for low ash melting characteristics typical for biomass [4].

An experimental research has been conducted successfully using a BFB (bubbling fluidized bed) test rig which burns pellets of Empty Fruit Bunch. The biomass waste is produced in a very large amount from palm oil mills [6].

## **CONCLUSION**

It can be concluded from those two experiments that briquette dimensions should be as small as possible but their composing particles should be as coarse as possible. Combining those requirements, each briquette should be an impervious single very small unit. The most appropriate furnace type is fluidized bed, either circulating or bubbling types.

## **ACKNOWLEDGEMENTS**

The paper combines results of an international collaborative research project coordinated by Prof. I. Naruse from the Toyohashi University of Technology (Japan) with another independent research carried out in the Gadjah Mada University. The author wishes to

acknowledge gratefully The New Energy and Industrial Technology Development Organization (NEDO-Japan) for the three year financial support, and also to thank his former students Ibnu Rois al Hakim and Taufan Enggar for their excellent Research Assistances. Another student, Gama Ajiyantono, is very helpful during figure preparations as well.

## REFERENCES

- [1] Grover, P.D. and Mishra, S.K. (1996) Biomass briquetting: Technology and Practices, *Field Doc 46, FAO-Regional Wood Energy Dev. Prog. In Asia*, pp. 1-43.
- [2] Kwong, P.C.W., Wang, J.H., Chao, C., Cheung, C.W. and Kendall, G. (2004) Effect of co-combustion of coal and rice husk on combustion performance and pollutant emissions, *Proceedings of the 7<sup>th</sup> Asia-Pacific Symp. on Combustion & Energy utilization*.
- [3] Saptoadi, H. (2004) The best composition of coal-biomass briquettes, *Proceedings of coll. Workshop on Energy, Environment and new trend in Mech. Eng.*, pp 91–105.
- [4] Kettunen, S. (2004) Foster Wheeler experience in biomass and clean fossil fuel power plant technology, *Proceedings of the Int. Workshop on Biomass & clean fossil fuel power plant technology*, pp. I-1-20.
- [5] Sutanto, I. (2004) Biomass to energy projects in Indonesia, *Proceedings of the Int. Workshop on Biomass & clean fossil fuel power plant technology*, pp. 1-9.
- [6] Ino, T. et al. (2004) Fluidized bed combustion test results of Empty Fruit Bunches, *Proceedings of the Int. Workshop on Biomass & clean fossil fuel power plant technology*, pp. 49-57.